

BR150SC	
Capacità massima Lt:	0,6
Capacity	
Autonomia h :	3,5
Autonomy	
Consumo max Lt/h:	0,2
Consumption	
Potenza Kw:	1,4
Power	
Peso Kg:	2,2
Weight	

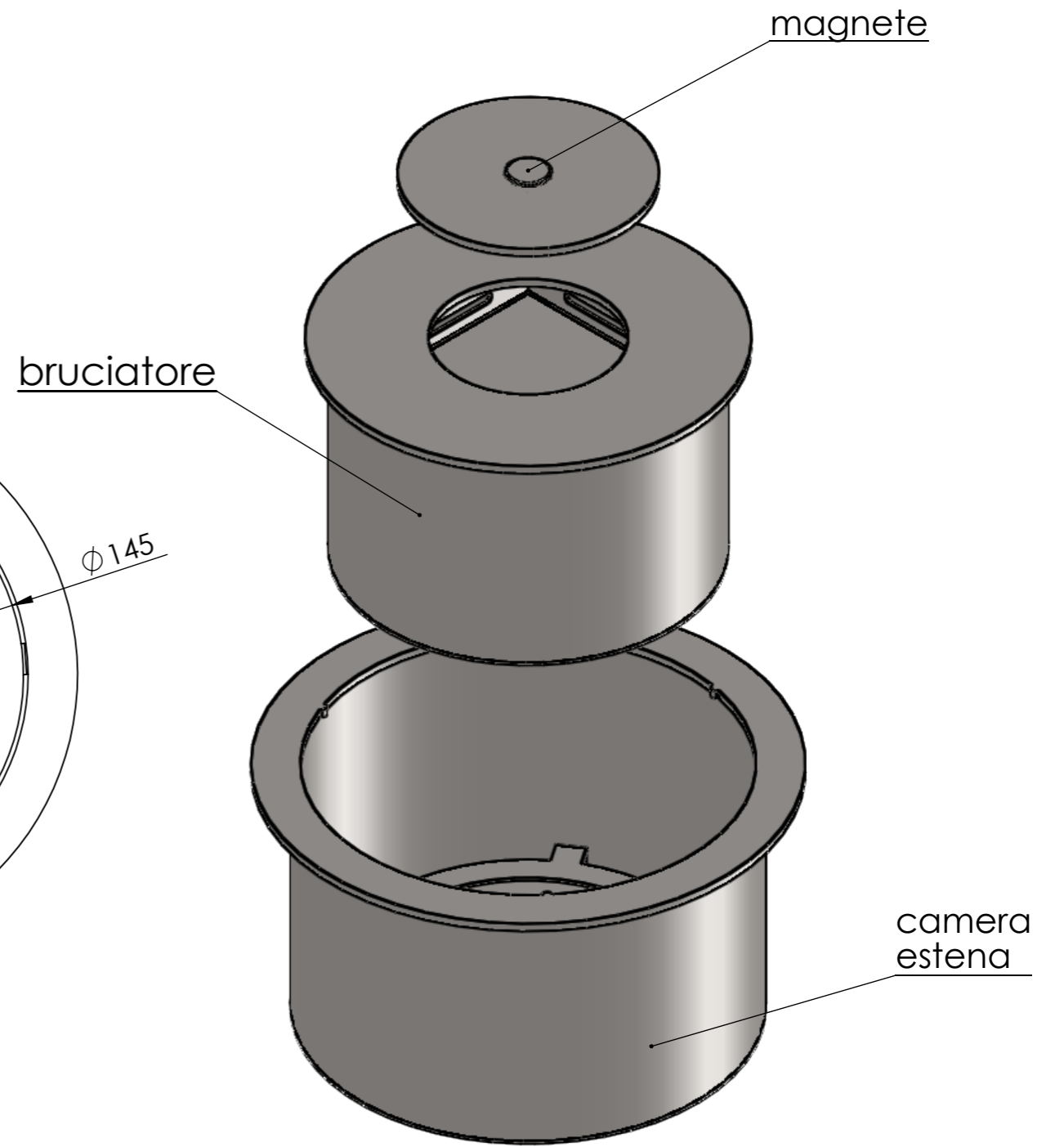
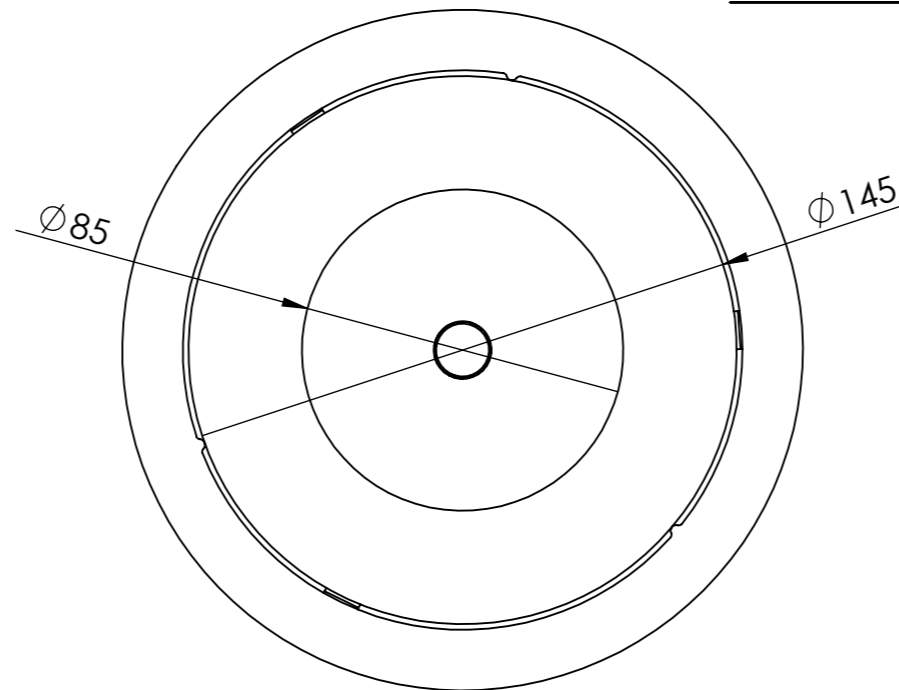
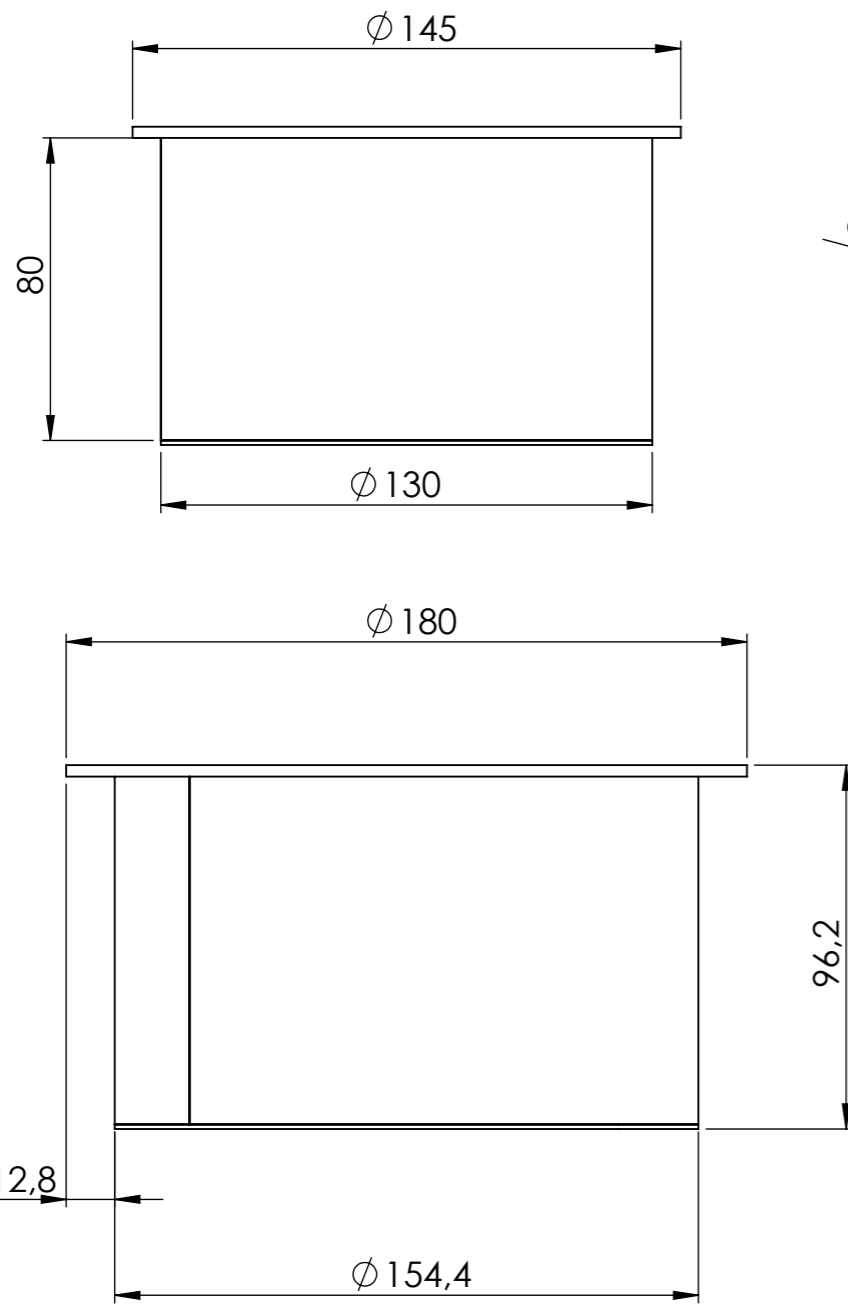
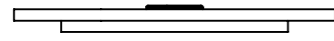

SE NON SPECIFICATO: QUOTE IN MILLIMETRI FINITURA SUPERFICIE: TOLLERANZE: LINEARE: ANGOLARE:		FINITURA:  SAT		SBAVATURA E INTERRUZIONE DEI BORDI NETTI		NON SCALARE IL DISEGNO		REVISIONE 08.2019	
DISEGNATO		NOME		FIRMA		DATA		TITOLO:	
VERIFICATO		FB				09/19		<b>bioKamino®</b>	
APPROVATO								N. DISEGNO	
FATTO								BR150SC	
QUALITA'						MATERIALE: INOX		A3	
						PESO: ---		SCALA:1:5	
								FOGLIO 1 DI 1	